

Quick Reference Guide to Teac 80-8:

Page:

- 2 Necessary repairs and attention points
- 3 Motor Caps pin layout & Omron Relays on the audio cards
- 4 Testing voltages of the Power Supply
- 5 Audio cards: location of Electrolytic Capacitors
- 6 Audio cards: parts list of Electrolytic Capacitors
- 7 Audio cards: location of adjustment pots
- 8 System Control Board: layout of IC's & Electrolytic Capacitors



Teac 80-8 | Necessary repairs and attention points

Here is the list of the necessary things to do:

- before power on:** replace the 2 sparkkillers on the power switch, 2x 4700pF.
- replace** caps on Power Supply.
- replace** all caps on audio cards, see later in this QRG.
- replace** caps on System Control Board.
- replace** capstan belt and counter belt.
- replace** 3 motor caps:
 - 2,8 μ F capstan motor, diam. 30mm
 - 5 μ F (x2)reel motors, diam. 40mm
- I understand it's now a known problem with the 80-8 that several capacitors in the master bias oscillator are bad by now, and require replacement.

There are also points that need attention:

- perhaps **replace** 3 bearings:
 - left roller: 626VV
 - flutter roller: LF-740ZZ = SKF W 627/4 R-2Z (2x)
 - pinch roller: 394928A = 626
- check** bulb lights VU meters and one in tape counter(!) 5V.
- replace** foam strip at audio cards.
- check** cue lever locking functionality / mechanism.
- Calibration is at 185 nWb/m
 - 0 VU referenced to 3 dB above 185 nWb/m of tape flux
 - 0 dB = 1 V
 - Line input + line output = -10 dB = 0,3 V unbalanced
- track 1 is closest towards the front, track 8 is the closest to the face plate.



flutter bearing

- 5.2.4 quick adjustment
- 5.3.1b removal control board

Motor Caps:

Reel motors:

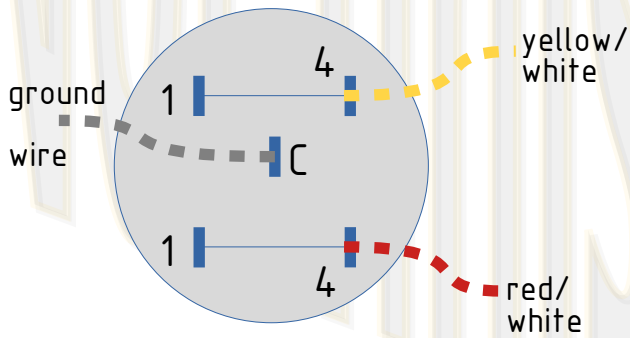

Capstan motor cap:

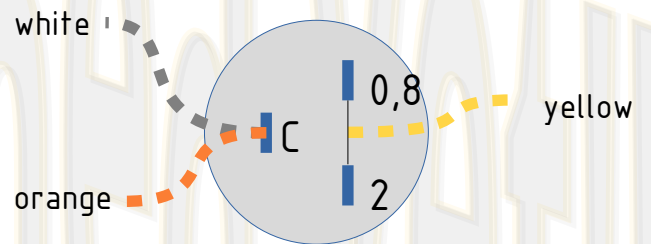

Omron Relays on the audio cards: type LZN2 14Z7K1 24 V DPDT

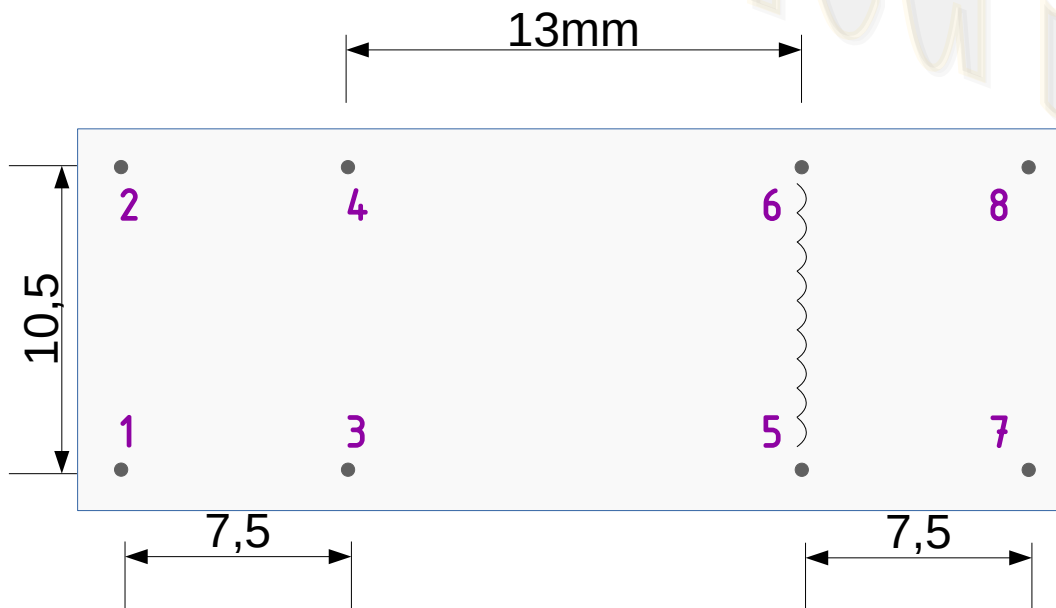

In **rest**, 3-7, 4-8 make contact. When **24 V** applied, 1-7, 2-8 make contact. Try G6AK 2W 24DC at reichelt for substitute (not tested!)

Testing voltages of the Power Supply (5.2.3)

In order to test the Power Supply, voltages need to be checked according to the SM. However, these points are almost impossible to probe.

So these points that I indicated below, at the legs of components, are connected to these same test points mentioned in the SM, but are much easier to probe on the PCB. But be aware of possible insulated legs on the components when you are measuring!

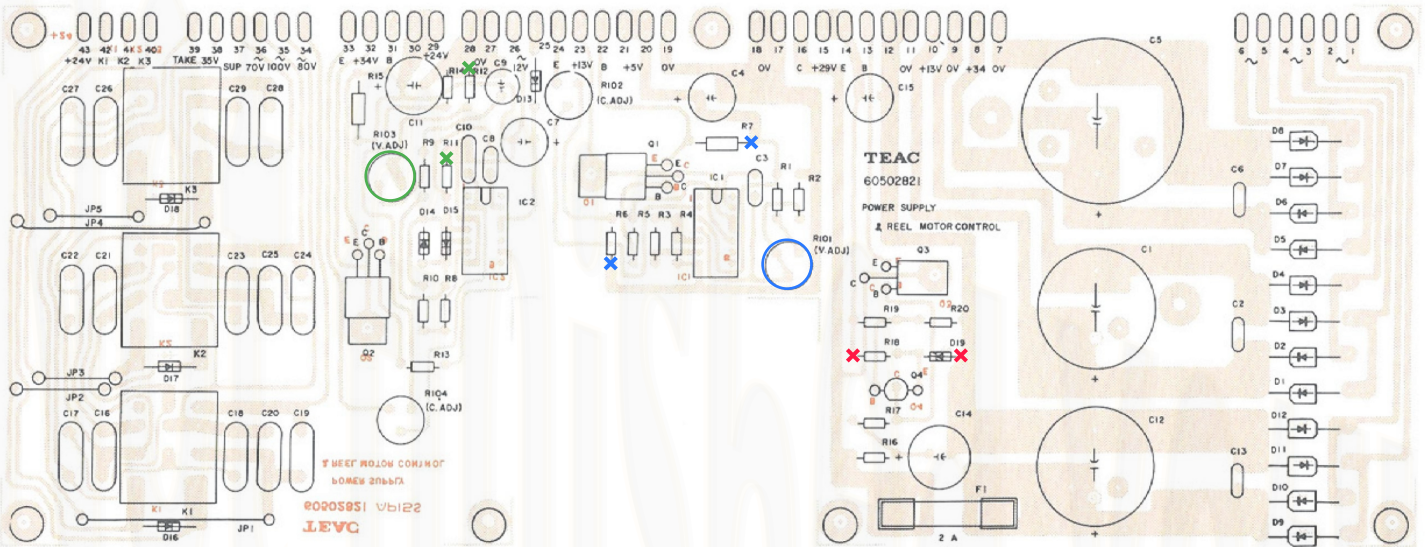

- 1) ■ The voltage should not fluctuate beyond +27.5V and +30.5V when PLAY and STOP is quickly repeated
- 2) ■ The voltage should be within the range of +5.0V and +5.3V. If the reading is off spec, adjust R101.
(do NOT touch R102!)
- 3) ■ The voltage reading should be between +23V and +25V. If it is off spec, adjust R103 (10K)
(do NOT touch R104!)

Location of electrolytic capacitors on the Power Supply Board

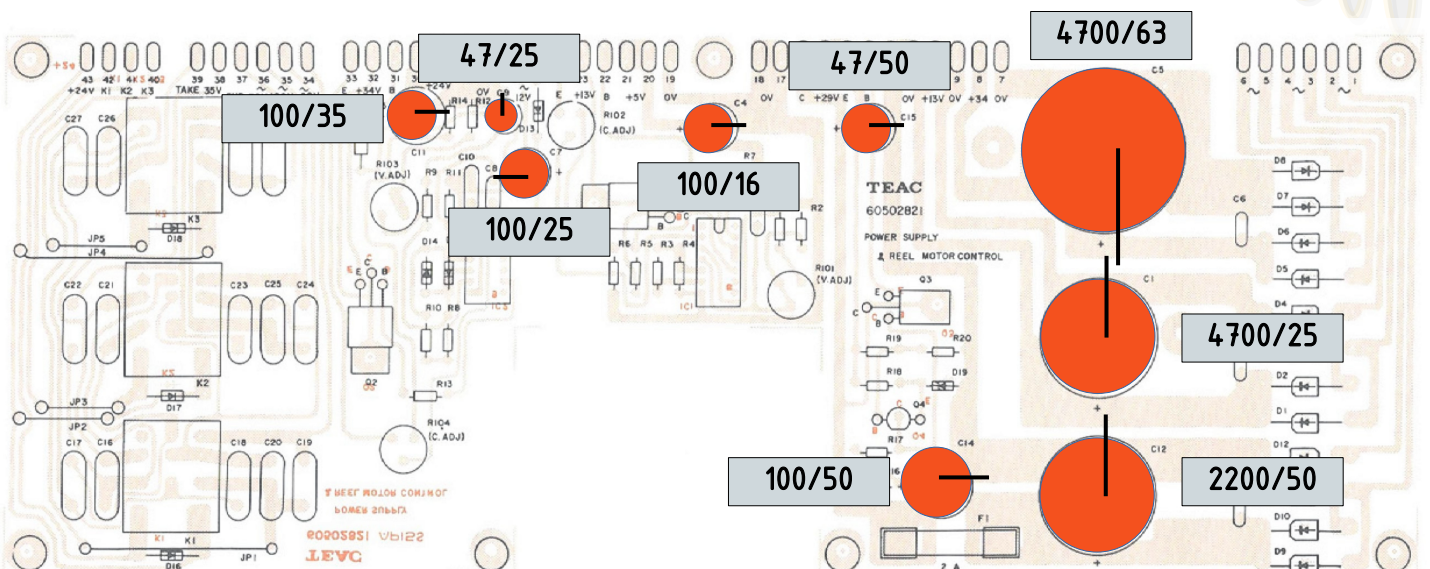

Audio cards: location of electrolytic capacitors

9x in this quadrant

0,47	6x
2,2	
10	
22	

12x in this quadrant

0,47	3x
2,2	
4,7	
10	
22	
47	2x
100	

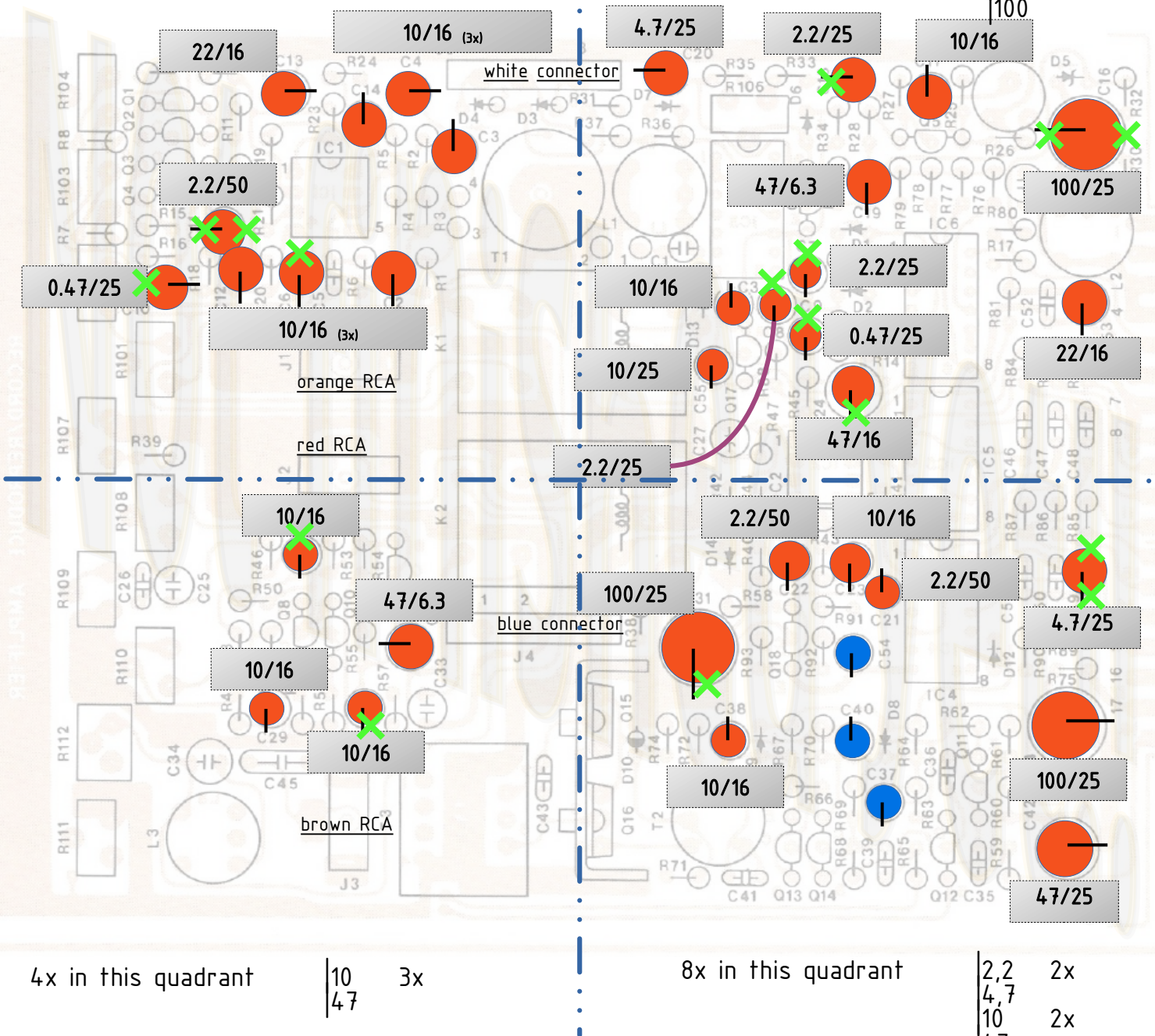

4x in this quadrant

10	3x
47	

8x in this quadrant

2,2	2x
4,7	
10	2x
47	
100	2x

- = electrolytic capacitor with the minus on the bottom side
- = BEWARE of PCB top layer solder connection on that leg of the component!!

Audio cards: parts list of electrolytic capacitors

#	schematic	μF	volt	μF	count/card	cards	total
1	C2	10	16	0.47	2	8	16
2	C3	10	16				
3	C4	10	16	2.2	6	8	48
4	C6	10	16	4.7	2	8	16
5	C7	2.2	25	10	14	8	112
6	C8	2.2	25	22	2	8	16
7	C9	0.47	25	47	4	8	32
8	C10	0.47	25	100	3	8	24
9	C11	2.2	50				
10	C12	10	16		33		264
11	C13	22	16				
12	C14	10	16				
13	C16	100	25				
14	C17	10	16				
15	C18	2.2	25				
16	C19	47	6.3				
17	C20	4.7	25				
18	C21	2.2	50				
19	C22	2.2	50				
20	C23	10	16				
21	C24	47	16				
22	C28	10	16				
23	C29	10	16				
24	C30	47	6.3				
25	C31	100	25				
26	C32	10	16				
27	C38	10	16				
28	C42	47	25				
29	C44	100	25				
30	C49	4.7	25				
31	C53	22	16				
32	C55	10	25				
33	C unkn.	10	16				
tant	C37	22	16				
tant	C40	22	10				
tant	C54	47	6.3				

Beyond certain serial numbers Teac started swapping certain el. caps for tantalum and vice versa, but with different value however. So check your board!!

Head Block: location of heads (Teac terminology)

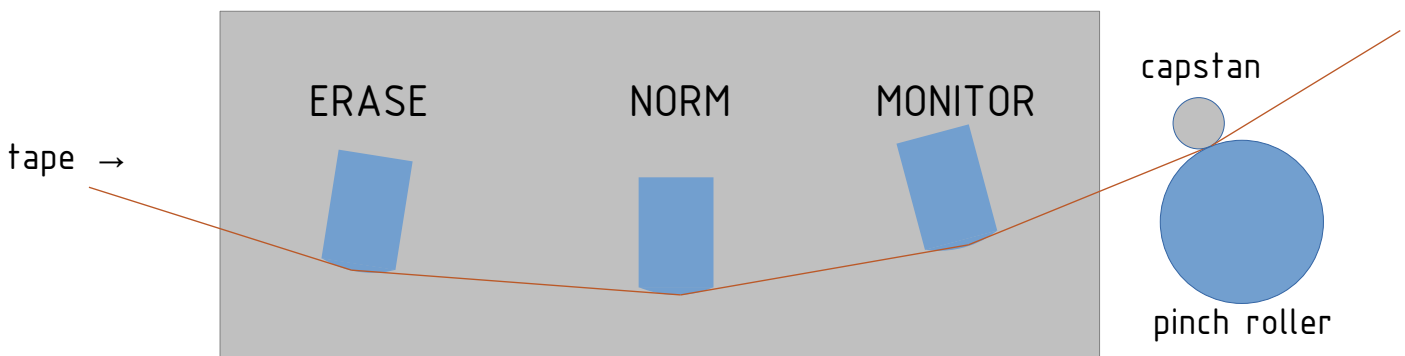

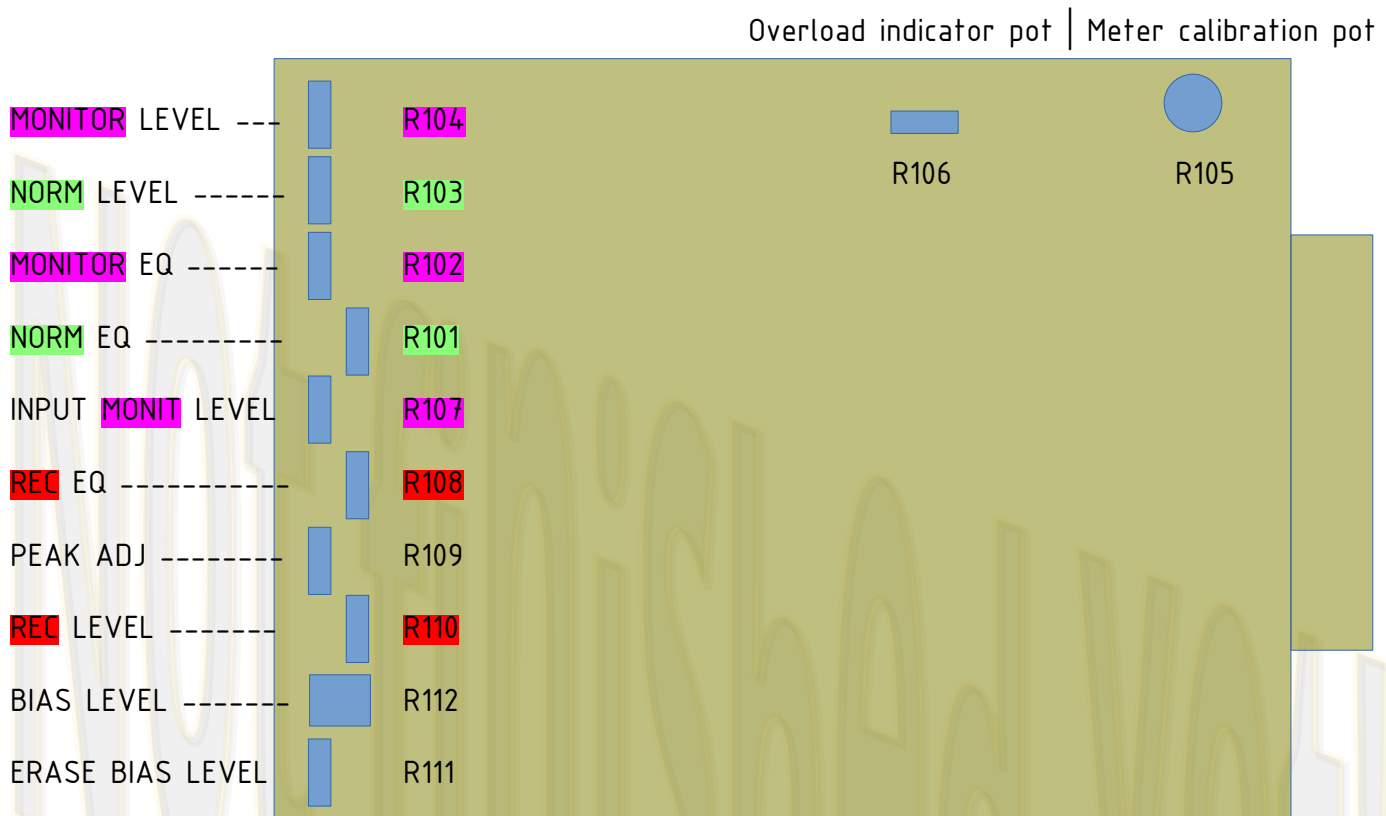

Audio calibration instructions: the quick version (full version in SM)

1. operating level

- set output select to MONITOR
- play reference section
- adjust MONITOR LEVEL pot R104 for 0,3 V on output
- switch output select to NORMAL, play ref section
- adjust NORM LEVEL pot R103 for 0,3 V on output
- adjust METER pot R105 to read 0VU (use extender card)

2. frequency response

- set output select to NORMAL
- play frequency section
- adjust NORM EQ pot R101 so 1 kHz and 10 kHz are flat
- then see if response is ± 2 dB at 12,5 kHz and 16 kHz
- switch output select to MONITOR
- adjust MONITOR EQ R102 so 1 kHz and 10 kHz are flat

3. record calibration

- set output select to INPUT
- apply 1 kHz -10 dB 0,3 V at INPUT
- rotate front panel knob to 2 o'clock position and mark with pencil
- adjust INPUT MONIT LEVEL pot R107 to read 0 VU
- adjust Overload indicator pot R106 to light just as input level is increased to 1 V (use extender card)

4. bias level

- record 10 kHz test tone
- set output select to MONITOR
- adjust the front panel knob so that VU meter reads a conveniently read value
- from fully CCW, rotate BIAS LEVEL R112 pot until peak VU is observed
- continue rotate until peak drops 3 dB

5. record level

- set the front panel knob to the previously marked 2 o'clock position
- record 1 kHz, 10 dB 0,3 V signal
- set output select to MONITOR
- adjust REC LEVEL pot R110 to obtain 0 VU on the meter
- set output select to NORM
- reproduce recorded 1 kHz signal and check 0 VU $\pm 0,5$ dB

6. record equalisation

- There are two trim pots for Record Equalization on the 80-8. One, marked REC EQ R108 is for shifting the high frequency peak, and the other, marked PEAK ADJ R109 is for raising or lowering the peak.
- record 1 kHz 0 VU -10 dB signal
 - set output select to MONITOR
 - raise record frequency to 15 kHz and check if the difference is within ± 2 dB
 - if not, adjust REC EQ pot R108
 - adjust REC EQ R108 for frequencies from 10-15 kHz, adjust PEAK ADJ pot R109 for freq. above 15 kHz

The audio calibration must be executed in the given order!

System Control Board: layout of IC's

All IC's are 7400-series: SN74XXN

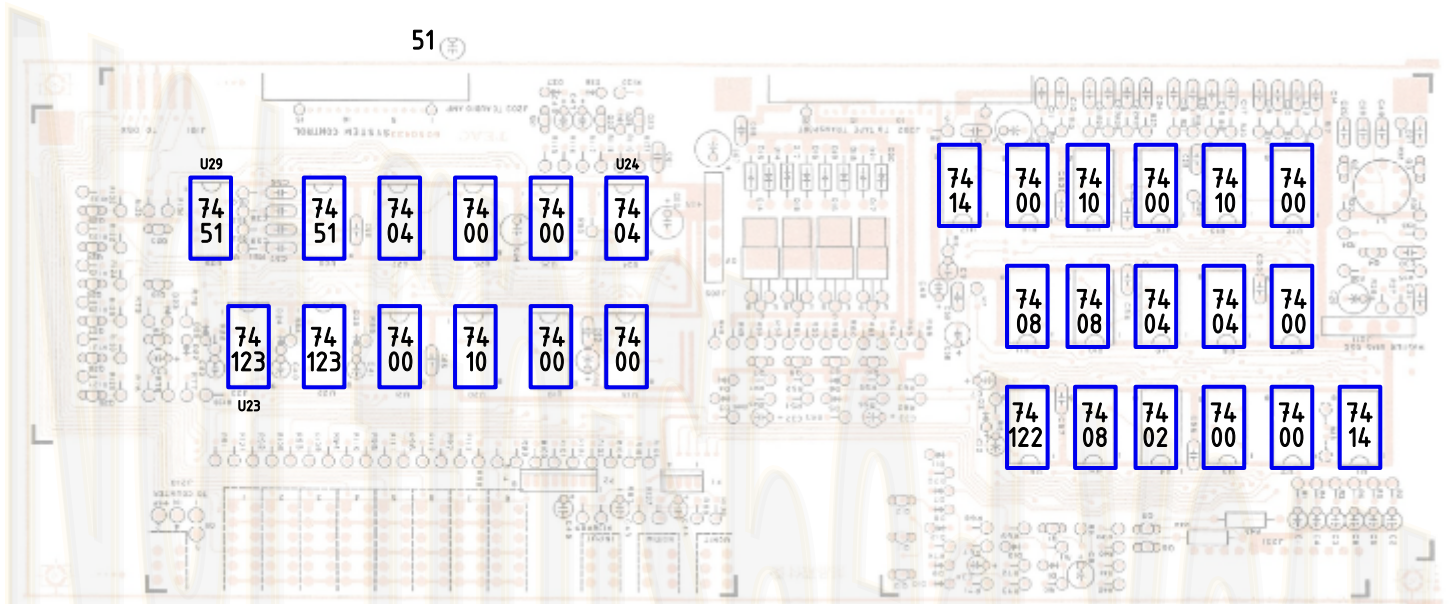

System Control Board: layout of electrolytic capacitors

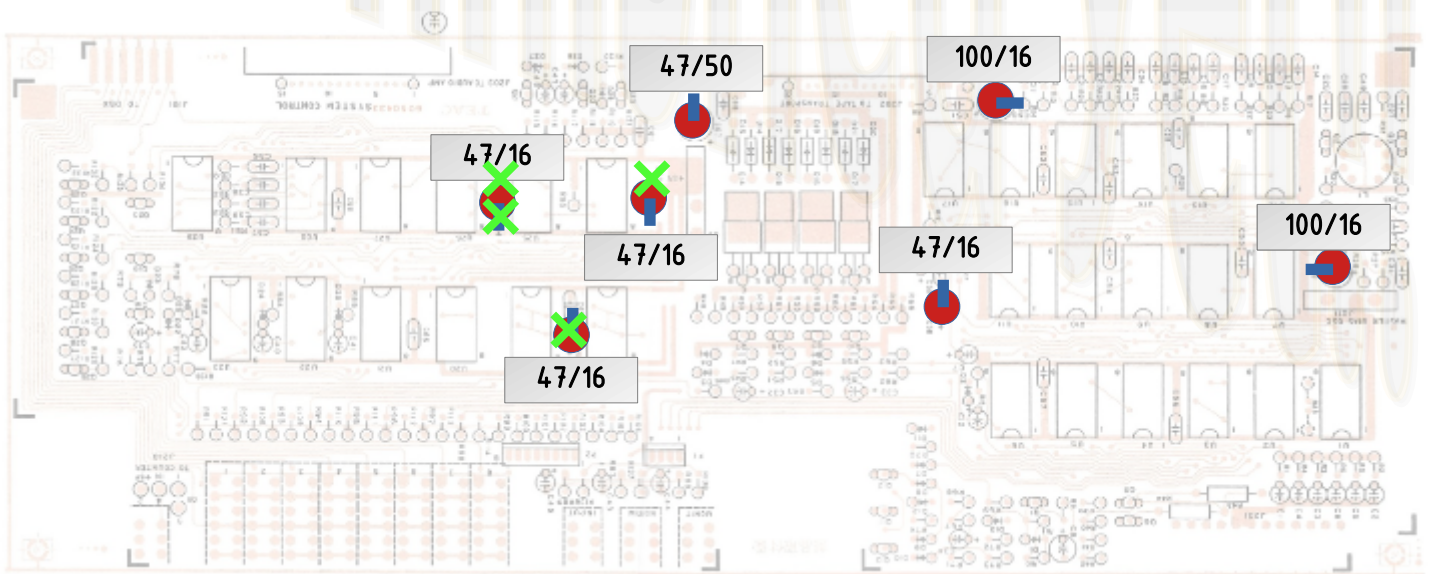

Caps list:

5x 47 μ F
2x 100 μ F